

Wheeler-Rex 9015 Plastic Pipe Beveler

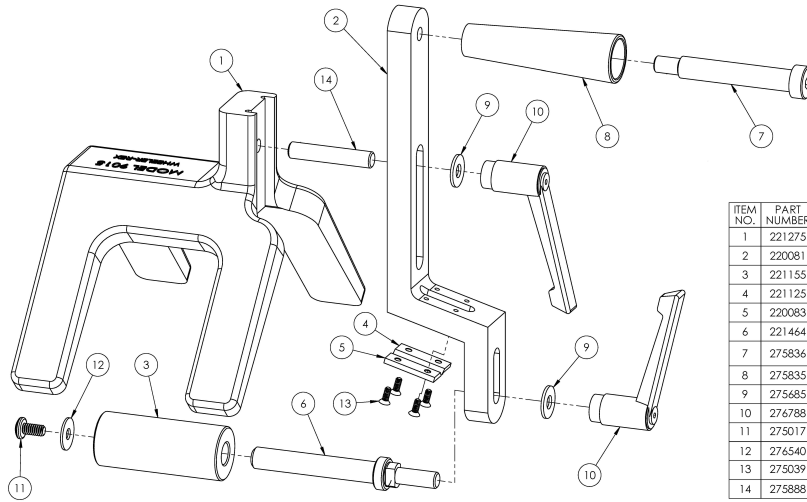

ITEM NO.	PART NUMBER	DESCRIPTION	QTY.
1	221275	SADDLE MACHINING	1
2	220081	BLADE BAR MACHINING	1
3	221155	ROLLER	1
4	221125	WEAR BAR	1
5	220083	BEVEL BLADE	1
6	221464	ROLLER SHAFT	1
7	275836	2 3/4" x 1/2" Socket Head Shoulder Screw	1
8	275835	HANDLE	1
9	275685	5/16" FLAT WASHER	2
10	276788	CLAMP LEVER	2
11	275017	1/4-20 x 1/2" Pan Head Phillips	1
12	276540	1/4" FLAT WASHER	1
13	275039	#6-32 x 3/8 Flat Head Phillips Screw	4
14	275888	3/8-16 x 2 THRD STUD	1

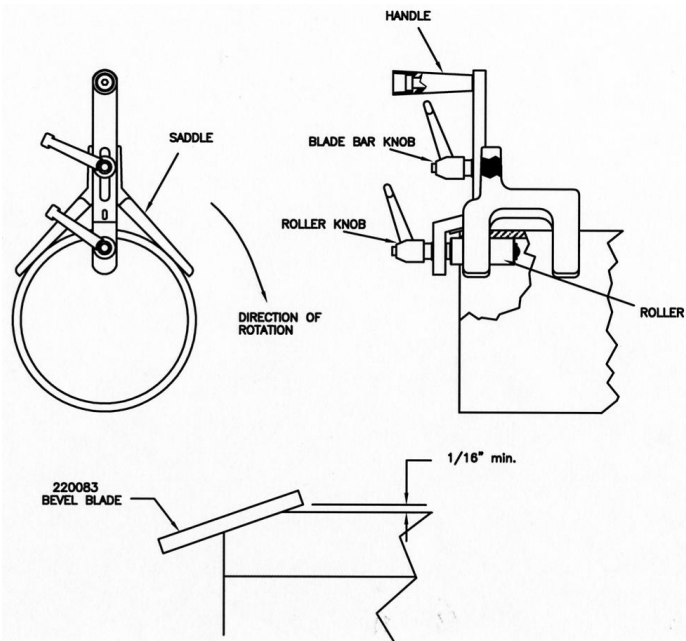

Operating Instructions

1. Loosen roller knob and adjust roller to approximate wall thickness.
2. Loosen blade bar knob and place beveler on pipe with the saddle on pipe OD. Pull the blade bar up until roller firmly contacts pipe ID. Tighten blade bar knob.
3. Grasp the handle and rotate beveler clockwise exerting a slight inward pressure.
4. Continue to rotate the beveler until the desired bevel is obtained.

If the next piece of pipe to be beveled is the same diameter and wall thickness, no further adjustments are required.



Wheeler-Rex
Ashtabula, OH 44004
Tel: 800-321-7950
Fax: 440-992-2925
www.wheelerrex.com